

392-318 ENGINE TO TRANSMISSION ADAPTER

ENGINE APPLICATION YEARS/CID:	V8 CHRYSLER 54-58, DODGE 53-58, DESOTO 52-58, PLYMOUTH 55-58
TRANSMISSION APPLICATION YEAR/MODEL:	SMALL BLOCK MOPAR AUTOMATIC A727, 618, 518, 904, 999 10 OR 11" FLEXPLATE; MANUAL TRANS. USING STOCK OR AFTERMARKET BELLHOUSING
STARTER USED	1966-1999 MOPAR 2 BOLT STARTER, GEAR REDUCTION OR DIRECT DRIVE
MATERIAL / MACHINING METHODS	WILCAP CNC MACHINED CAST ALUMINUM ADAPTER PLATE, STEEL FLEXPLATE, ALUMINUM CRANKSHAFT SPACER, DOWEL PINS, GRADE 8 CRANKSHAFT ATTACHMENT BOLTS, ALLOY ENGINE TO ADAPTER FASTENERS. SPECIAL FLYWHEEL FOR MANUAL TRANS. ADAPTERS
ADDITIONAL PARTS NEEDED	ENGINE, TRANSMISSION, BELLHOUSING FOR MANUAL TRANS, STARTER, OIL FILTER ADAPTER (IF NEEDED)

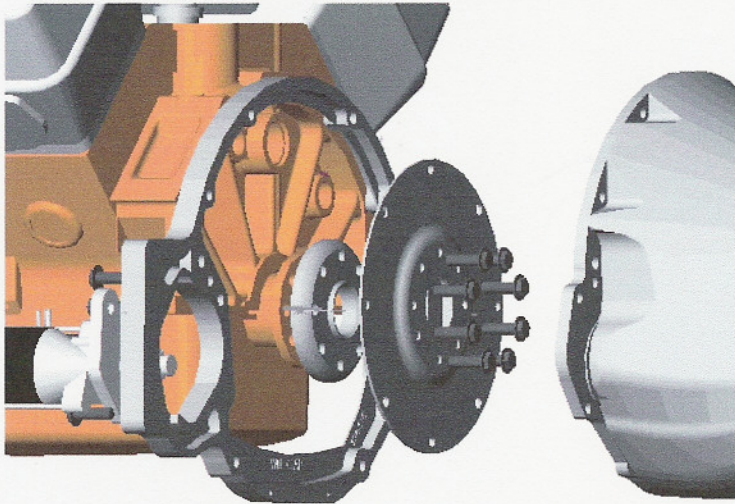

NOTES; The 392-318 has ears the protrude from the sides for use in mounting the engine or they may be trimmed off if they get in the way of your particular application. Unlike our competition NO modification of the starter nor drilling of the bell housing or engine is necessary. By adding one of our Wilcap steel or aluminum standard transmission flywheels and pilot bushing and your stock Mopar Small Block Mopar bellhousing you can use a three, four, five, or six speed manual transmission. We can supply the starter. Complete instructions are included for installing the adapter. We do not supply information regarding engine or transmission installation in to specific frames, bodies, etc. This is the responsibility of the customer and care should be taken to address the issues of motor and transmission mounts, driveline, body and frame clearance, gear ratios, etc. BEFORE the purchase of the engine to transmission adapter.

WILCAP COMPANY
P.O. BOX 763, PISMO BEACH, CA 93448
(805) 481-7639 FAX 343-5000
www.wilcap.com
Copyright 2003 All rights reserved.