

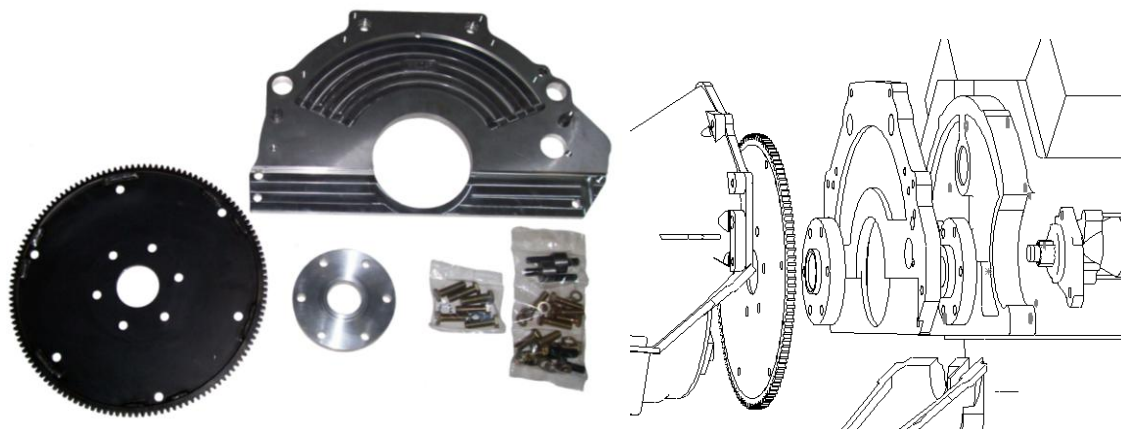

312-350

ENGINE TO TRANSMISSION ADAPTER

| | |
|-------------------------------|---|
| ENGINE APPLICATION YEARS/CID: | FORD/MERCURY V8 256, 292, 312 1954-1964 |
| TRANS APPLICATION YEAR/MODEL: | GM AUTO PG, TH350, 400, 700R4, CHEVY OR GM UNICASE |
| STARTER USED: | MODIFIED MOPAR 2 BOLT GEAR REDUCTION DRIVE "MINI" STARTER |
| MATERIAL / MACHINING METHODS: | WILCAP CNC MACHINED, BLANCHARD GROUND, ALUMINUM ADAPTER PLATE, STEEL FLEXPLATE W/ NEW RING GEAR, ALUMINUM CRANKSHAFT SPACER, DOWEL PINS, GRADE 8 CRANKSHAFT ATTACHMENT BOLTS, ALLOY ENGINE TO ADAPTER FASTENERS. |
| ADDITIONAL PARTS NEEDED: | STARTER, TRANSMISSION, DUST COVER |



NOTES;

1. Due to the starter location, some small modification of the transmission case is necessary.
2. We can supply the starter. Part number and application is supplied in the kit.
3. Complete instructions are included.

We do not supply information regarding engine or transmission installation in to specific frames, bodies, etc. This is the responsibility of the customer and care should be taken to address the issues of motor and transmission mounts, driveline, body and frame clearance, gear ratios, etc. BEFORE the purchase of the engine to transmission adapter. We can assist you with information and dimensions of the adapter prior to the start of your project so feel free to contact us with any questions.

WILCAP COMPANY
P.O. BOX 763, PISMO BEACH, CA 93448
(805) 481-7639 FAX (805) 481-9367
www.wilcap.com
 Copyright 2008 All rights reserved.